

# Genkotsu-Robot 2 High Speed Picking and Assembly Robot

## FANUC Robot *M-2iA*



### Features

- The FANUC *M-2iA* robot is a high-speed picking and assembly robot.
- Six models are available to meet the needs of multiple space requirements.
  - FANUC Robot *M-2iA/3A*, *M-2iA/3AL*  
six-axis model with a three-axis wrist. This model is designed for arranging and assembly.
  - FANUC Robot *M-2iA/3S*, *M-2iA/3SL*  
Four-axis model with a single-axis wrist. This model is designed for picking from a conveyor at extremely high rates.
  - FANUC Robot *M-2iA/6H*, *M-2iA/6HL*  
Three axis model with no wrist rotation for ultra high speed picking/packing operations.
  - Long-arm models cover a wider operating area.
- Able to withstand high-pressure steam cleaning - IP69K rating.
- Food adaptation option is available with a high-quality surface treatment and food-grade lubricant, making it ideal for handling food and beverage products.
- Ready to be equipped with the latest intelligent features including FANUC *iR*Vision and force sensing.

### Application system



Food picking with four-axis *M-2iA/3SL*

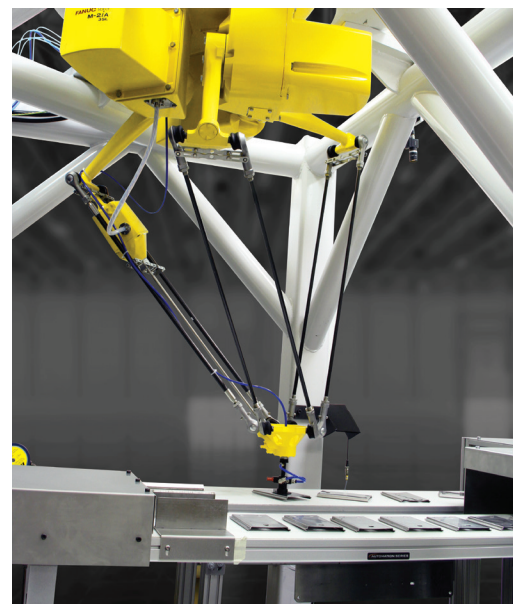

High speed sorting of metal plates with long-arm *M-2iA/3SL*

# FANUC Robot M-2iA

## Operating space

**M-2iA/3A, M-2iA/3AL**

**M-2iA/3S, M-2iA/3SL**

**M-2iA/6H, M-2iA/6HL**

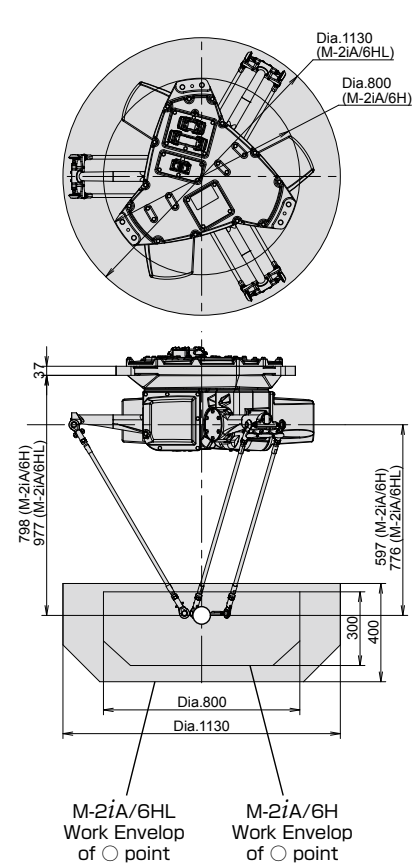
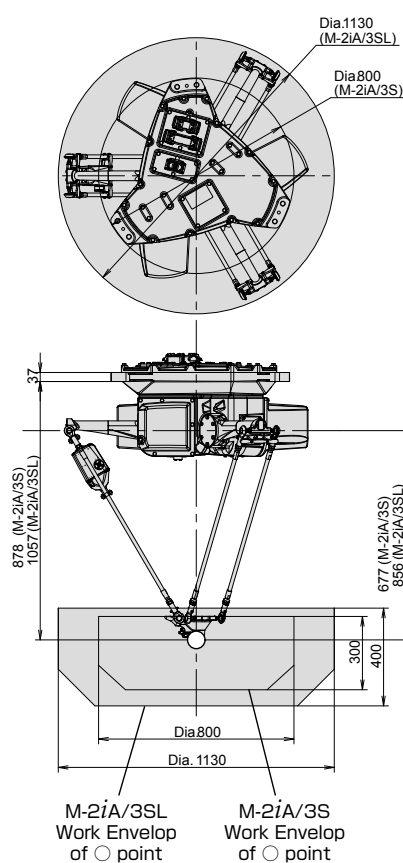
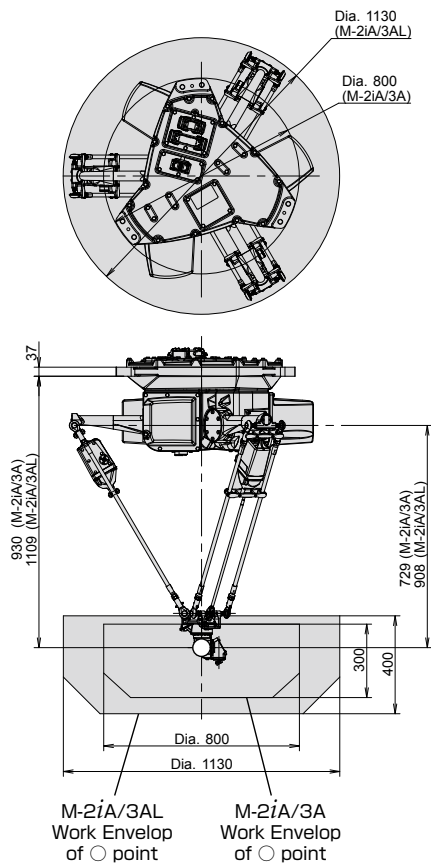

## Specifications

Item	Specifications		
	M-2iA/3A, M-2iA/3AL (Note3)	M-2iA/3S, M-2iA/3SL (Note3)	M-2iA/6H, M-2iA/6HL (Note3)
Type	Parallel link mechanism		
Controlled axes	6 axes (J1, J2, J3, J4, J5, J6)	4 axes (J1, J2, J3, J4)	3 axes (J1, J2, J3)
Installation	Ceiling mount		
Motion range (Maximum speed) (Note1)	J1-J3	Diameter 800 mm, height 300 mm (Note3) Diameter 1130 mm, height 400 mm	
	J4	720° (1700°/s) 12.57 rad (29.67rad/s)	720° (3500°/s) 12.57 rad (61.06rad/s)
	J5	300° (1700°/s) 5.24 rad (29.67rad/s)	-
	J6	720° (1700°/s) 12.57 rad (29.67rad/s)	-
Max. payload at wrist	3 kg	3 kg	6 kg
Repeatability	± 0.1 mm		
Drive method	Electric servo drive by AC servo motor		
Mass (Note2)	140 kg	130 kg	125 kg
Installation environment	Ambient temperature : 0~45°C		
	Ambient humidity		
	Normally : 75%RH or less (No dew, nor frost allowed) Short term : Max. 95%RH or less (within one month)		
	Vibration : 4.9 m/s <sup>2</sup> (0.5G) or less		

Note 1) In case of short distance motion, the axis speed may not reach the maximum value stated.

Note 2) Without controller.

Note 3) For long arm specification (M-2iA/3AL, M-2iA/3SL, M-2iA/6HL).

# FANUC

FANUC AMERICA CORPORATION  
3900 WEST HAMLIN ROAD  
ROCHESTER HILLS MI 48309-3253



MARKETING@FANUCAMERICA.COM FANUCAMERICA.COM 888-FANUC-US